

Pricing Guide
December 2012



Contents

Forward

Ordering Information	3-4
Materials	5
Care and Maintenance	6

AERO Design Concept

Design Team	7
Wood Species & Finishes	8
Features & Benefits	
AERO Collection	9
Conference Tables	10
Media Units	11
Wire Management	12

Conference Tables

Round Tables	14
Square Tables	15
Telepresence Tables	16
Curved Boat Tables	17-21
Rectangle Tables	22-26
Wedge Tables	27-32
Video Conferencing Tables	
Conference Compliments	37-38

Media Units

Standard Height Credenza	34
20" H Credenza	35
Media Unit Optional Details	36

Buffet Credenzas

Conference Compliments

Hospitality Cart	40
Hospitality Table	40
Lectern	40



Ordering Information

Orders

All orders must be complete and in writing to avoid error or duplication. Review this Ordering Guide to ensure necessary information is included on your purchase. Omission of pertinent information may cause delays in production of your order.

Acceptance

Order acceptance is contingent upon credit approval. Accepted orders will be acknowledged with a CCN Acknowledgement Form; this document is final and binding. CCN International is not responsible for any misinterpretation unless notification is made to CCN within 10 days after order acceptance. CCN strives to clarify all purchase orders. In the event the catalog number and description differ, the catalog number will prevail. It is the customer's responsibility to check the Acknowledgement Form for errors. If a specific date is required for delivery, please indicate on your purchase order and we do our best to accommodate your request. All acknowledgements contain an estimated shipping date. Buyer may be held liable for storage charges if not ready to receive goods when orders are completed.

Prices

Customer agrees to pay for all items ordered from CCN in accordance with the published price list in effect at the date of order acceptance, or in the case of modified product, the factory quote. For quoted products, please include CCN quote number on your purchase order. Prices and specifications are subject to change without notice.

Terms and Discounts

Standard terms of sale for CCN are net thirty (30) days from date of invoice. All prices are quoted F.O.B. factory. Dealer discounts in effect between CCN and authorized CCN dealers will be honored from list price unless another agreement between both parties has been made. Finance charges will be assessed on overdue balances.

Deposit

CCN typically requests a minimum deposit of 50% prior to commencement or shipment of merchandise. CCN will request the exact amount required and the date due in writing. If you have been notified that a deposit is required, production will cease if deposit is not received by specified date. Your responsiveness to deposit requests may affect your lead-time.

Specifications

CCN International's ongoing product improvement program may result in changes in design, construction, or discontinued products without notice.

Changes and Cancellations

Any order changes or requests for cancellation after receipt of the CCN order acknowledgement are subject to our ability to conform and will be subject to a charge for our expense of materials, labor or other costs incurred by CCN, depending on the status of the order at the time of the change or cancellation request.

Return Goods Authorization

CCN will not accept the return of merchandise for any reason, without prior approval from CCN Management and Customer Service Department. Unauthorized returns will be refused.



Ordering Information

Shipping

CCN International orders will be shipped freight collect, bill third party or prepaid and added to the invoice. Shipments will be made “best way” unless a carrier has been specified by the purchaser. Large items such as reception desks must be shipped by a blanket wrapped carrier. All orders are shipped F.O.B. factory. Customer bears risk of loss or damage during shipment. We will make every attempt to ship orders complete and on schedule; however CCN reserves the right to make partial shipments. If a customer requests postponement of delivery after production has begun, CCN reserves the right to transfer furniture to storage at the customer’s own risk and expense or assess storage charges for furniture stored at CCN if space is available. Such transfer or storage shall be deemed delivery to customer for all applicable invoicing and payment. Specific delivery dates and times cannot be guaranteed. However, CCN recognizes the importance of coordinating delivery and installation and will forward requests to the trucking company. Under no circumstances will CCN or the trucking company be held responsible for any costs incurred due to late delivery.

Freight Damage and Claims

CCN is not liable for damage to furniture during transit or storage. Each shipment is packed by expert packers and responsibility for loss or damage lies with the carrier. Acceptance of the shipment from CCN acknowledges that all articles were packed properly and delivered in excellent condition. If concealed damage is discovered after unpacking merchandise notify the CCN immediately. Do not destroy packing materials until the shipment has been inspected. CCN suggest the words “subject to inspection” accompany the signature if the goods are curtained, and cannot be examined at the time of receipt. Please do not refuse any shipment, since by doing so you abandon all rights to the shipment. In all cases, the burden of proof for liability rests with the claimant. Good receiving practices and proper inspection of goods at the time of CCN International orders will be shipped freight delivery for all shipments will help to ensure all bona fide claims are collected from the transportation companies.

Warranty

CCN International warrants its furniture to be free from defects in material and workmanship under normal use and service for a period of ten years from the date of shipment. During this warranty period, CCN International’s obligation is limited only to the repair, or at its discretion, the replacement of such furniture which, upon return to factory or upon examination, proves to be defective. Any damages incurred during transit or damages incurred by the customer are not applicable under this warranty. CCN International makes no other warranty, either expressed or implied, including without limitation the product’s condition, its merchantability, or its fitness for any particular use or purpose.

Materials

Wood Products

All pieces are built with 45 lb. per cubic foot density engineered composite board, faced with quartersawn, rift cut, or plain sliced veneer. Painted components are built with medium density fiberboard. Exterior faces are premium grade veneer with specific veneer piece count determined by the width of the panel. Exposed edges are core banded with solid wood. The solid wood moisture at the time of application is between 6% and 8%.

Hardware used to build CCN Products

All case goods are equipped with adjustable levelling glides to assure level set-up and protection of floor coverings. All pieces are constructed square to sit level on flat surfaces. Hinged doors have fully concealed 3-way adjustable hinges. Doors with exposed hardware or bottom edge access have magnetic catch. Doors without pulls use a touch latch to open. Removable access panels are mounted using clips and a magnetic catch.

Construction of CCN Products

All case goods are glued and clamped with dowels or compressed splines. Pedestals and modesty panels are secured with screws and reinforced with glue cleats. Metal connectors are used in conjunction with type A screws where a knockdown joint is necessary. Any exposed undersides of panels or surfaces are sprayed with a high solids sealer to improve stability of the item under varying climate conditions.

Care and Maintenance

Certain precautions will preserve the beauty of your new wood furniture. High or low humidity extremes can cause warping, cupping, veneer checking, and joint separation. CCN will not be responsible for the humidity controlled care of the item once it leaves the factory.

Wet objects should be placed on coasters and writing should be done on a desk pad. Sharp metal objects such as keys, spring binders, and briefcase hinges should be kept from direct contact with the furniture. Bottoms of decorative items, such as flower vases and desk accessories should also be protected.

Contact between finish and certain plastic compounds may result in discoloration and finish damage. CCN recommends the use of felt pads under plastic telephones or other business machines feet to protect the finish.

Dust build-up, may scratch or dull the surface if not removed correctly. Simply wipe the surface with a cloth dampened with a mild detergent and dry with a soft towel. Avoid the use of ammonia based products, polish containing wax or silicone oils as they may cause damage if used over a long period of time. The finish is durable and resistant to most ordinary spills. However, spills should be wiped up promptly to avoid potential problems. Fingerprints, smoking residue, and other substances may accumulate on any finished surface. None of these contaminants will harm our finish, but they should be periodically removed to restore the finish to its original luster. Just wipe the surface with a cloth dampened with a non-wax containing polish or mild detergent solutions.

Anticipation of Color Change

All wood is photosensitive and changes color over time. This natural change occurs depending on the initial color of the wood and is especially apparent with lighter finishes. Some woods may change dramatically with exposure to direct sunlight. When ordering additional pieces for an existing installation, it is advisable to submit a finish sample with your order.

Design Team

Qdesign—Chicago, IL

Founded in 1994 by Mark Stenftenagel and Sal Graziano, Qdesign is the product design subsidiary of Whitney Inc., a full service architectural and interior design firm with over 70 combined years of experience.

Vision... Seeing the future while looking to the past.

Passion... Bringing enthusiasm and dedication to each design challenge.

Connection... Embodying clients' goals through collaboration and innovation.

Curiosity... Asking the questions that lead to enduring design solutions.

Design Inspiration & Goals

Minimalist

Purity of Form

Illusion of Super Thin Top

Full Power & Data Capabilities

Two-Tone Finish

Aesthetically Simple, Structurally Complex

Mixed Materials

Wood Species & Finishes

AERO FINISH PROGRAM

Part of AERO's unique aesthetic lies in the finish combinations. High-quality wood finishes are combined with painted surfaces. These color combinations can be selected to blend, or contrast offering unique design options and aesthetics.

PREMIUM WOOD VENEERS

- Plain Sliced Walnut
- Plain Sliced Maple
- Plain Sliced Cherry
- Quarter Cut Walnut
- Quarter Cut Maple
- Quarter Cut Cherry
- Rift Cut Oak

Please indicate vertical or horizontal grain direction of veneer for table bases and casegood components. The wood species listed above are finished with any of the CCN standard colors. For more information visit www.ccnintl.com/FINISHES.

FINISHES

Standard Wood Finishes

Our finish program is represented using a number system from the lightest (#2 clear) to the darkest (#8 dark brown). These standard shades compliment the various species in a variety of ways thus creating a broad pallet.

Mica Chalk

CCN new solid color finish offers a lush contrast when paired with our high-quality veneers. The top coat contains Mica flake that responds to light, lending a pearlescent quality.

Polished Stainless Steel

Metal accents

HARDWARE & DETAILS

Metal Accents

AERO's mixed materials design features metal accents in polished stainless steel.

Hardware

Pulls are available in polished stainless steel.

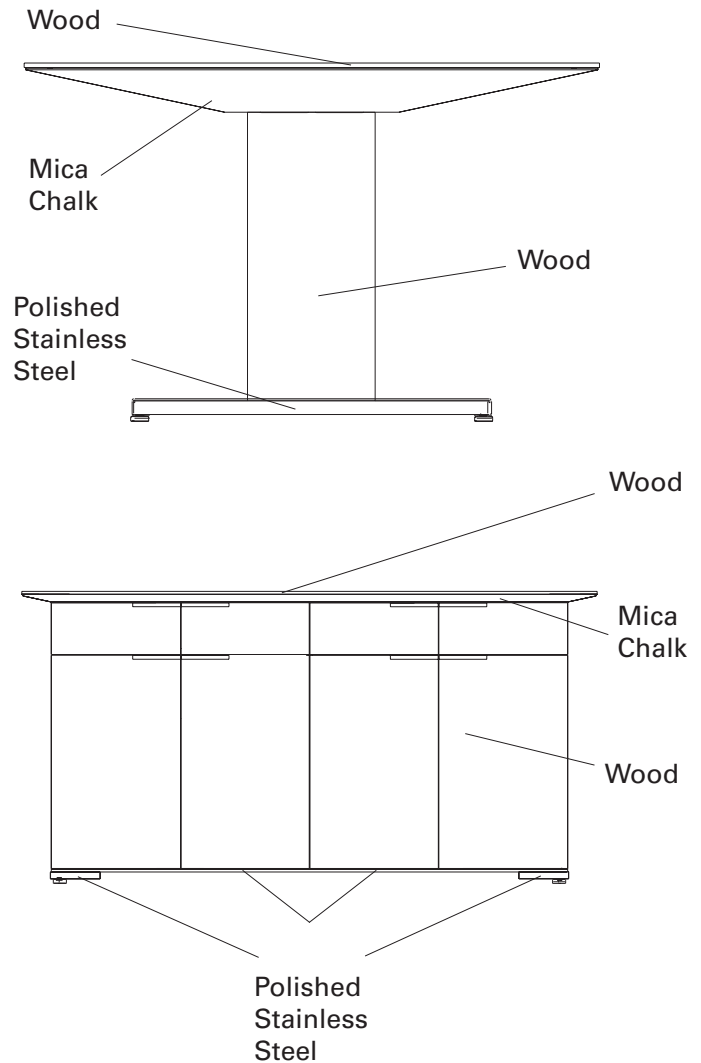

Features & Benefits

AERO Series

- **Light in Scale**
The AERO tables low-profile top and chamfered substructure provides a slim and sleek appearance. This aesthetic compliments current design trends for lighter scale and strong lines in the office environment.
- **DuoTone Finish**
The sub top is finished in our mica chalk creating dramatic contrast with the wood top and base finish.
- **Core-Banded Top**
Clean appearance with the edge protection and strength of solid wood.
- **Metal Accent Details**
Contrasting metal feet and bases add flair and strength to the overall design. Polished stainless steel is standard. (See page 8).
- **Collection of Items**
The AERO Series has all the elements needed for the conference room environment. Complimentary pieces, create a seamless visual aesthetic and optimize function with a breadth of media, hospitality, and storage solutions for any conference environment.



Features & Benefits

CONFERENCE TABLES

– Monocoque Construction

This construction technique supports the structural load by using the external skin. AERO's strength comes from its unitized shell construction. Thus, the entire table acts as a unit, distributing the load across of its members.

– Full Angular Sub-Top

Conceals entire wire management trough and structural elements.

– Panel Base Design

Provides minimal appearance with convenient access to wiring. Bases can be rotated 180° to accommodate wiring access that originates outside of the bases.

– Mixed Material Construction

Possesses the strength of steel and the beauty of wood. The use of a steel sub-frame amplifies the strength of the wood components within AERO to give the series exceptional rigidity.

– Component Construction

AERO is broken up into components to help streamline the installation process. The bases and trough are mechanically fastened for a quick set up for the wiring of power and data. The table top is self aligning, thus, reducing possibilities of human error during the installation process.

– Ease of Access

AERO allows for unobstructed power and data installation. Installers are able to work within the bases and trough without having to crawl underneath or on top of the table. Thus, increasing the speed and ease of installation, while reducing the potential for damaging the finished product. Access panels and trough are easily wired after installation as well.

– Matching Wood Doors

Utilizing CCN's unique veneer capabilities adds to the clean design by creating a sleek matched voice, power, and data access doors.



Features & Benefits

MEDIA CENTERS

– Media Walls/Units

The AERO Series features a number of multimedia display and storage solutions. They are all free standing, thus, eliminating the need for wood blocking in the walls, damage to finished walls, and misalignment of power and data connections. Each component uses a vertical convection riser to help vent media appliances, thus keeping them cool and functioning. Optional low profile credenzas increase the possible uses like public areas. Additionally, an optional teleconference camera shelf can be specified in wood or glass.

– Flat Panel Mounting Site

The screen is not bound by wood casework. This offers flexibility for flat screen mounting, changing, and upgrading in the future.



Innovative Wire Management

Each connection point on rectangular and video conferencing tables includes 2-power duplexes and 2-voice/data plates. Receptacles include flexible conduit so they may be daisy-chained together, or connected to an external power source. Hard wire options are available. Voice/Data plates are standard with 1-RJ11 and 1-RJ45. Contact factory for options.

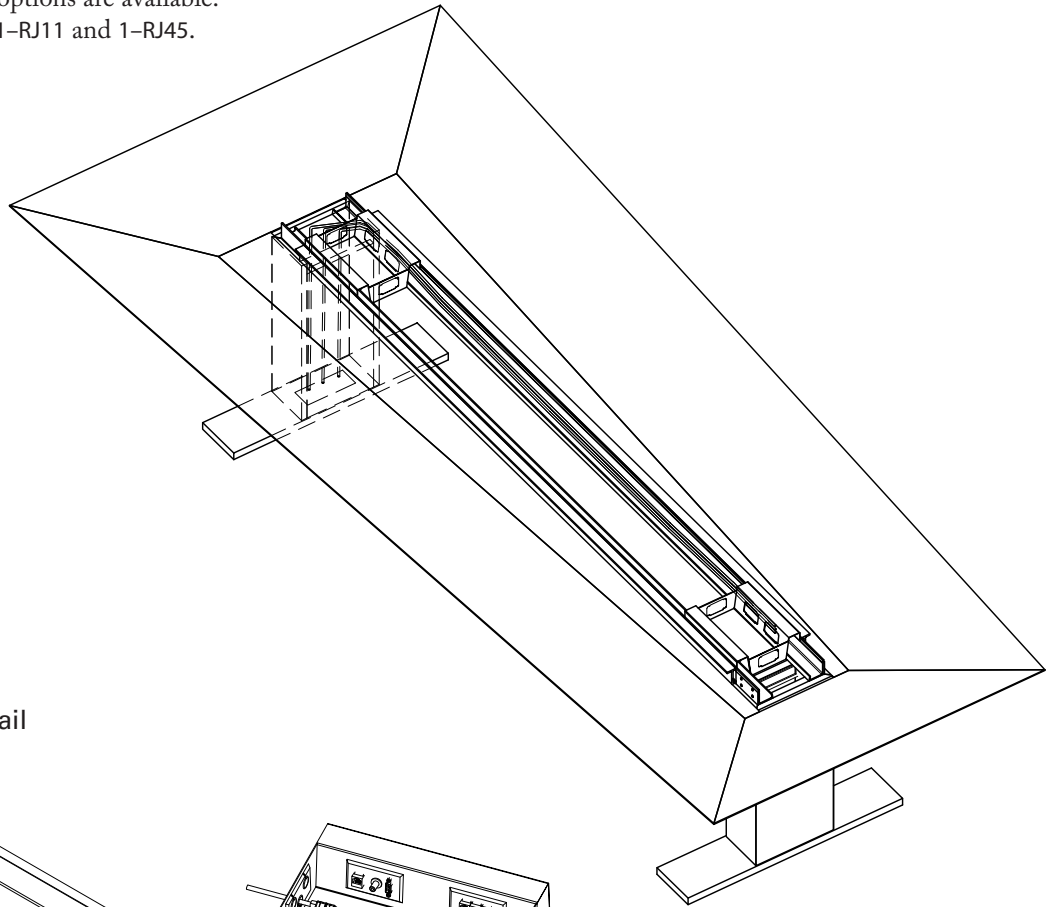

Voice Power Data Tray Detail

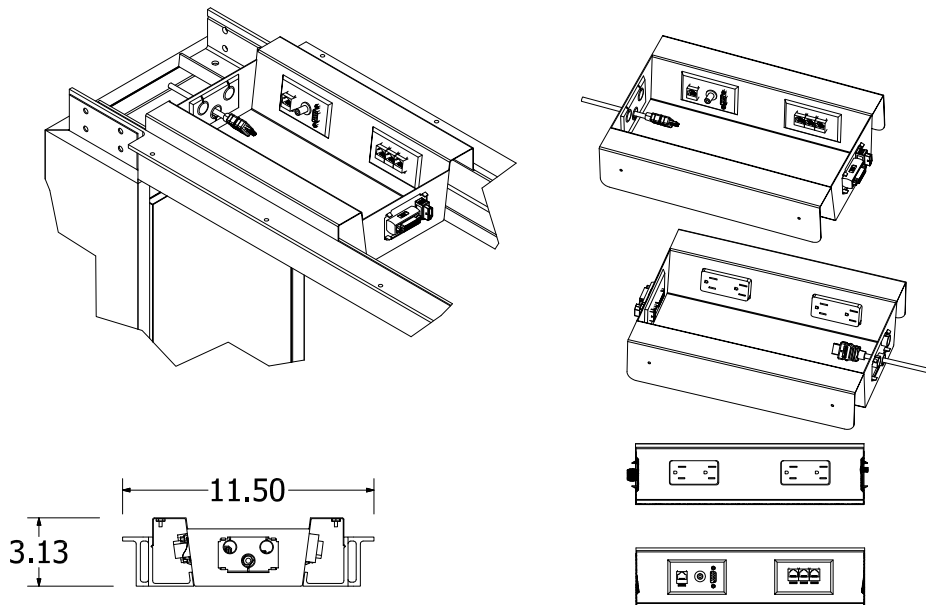

Conference Tables

AERO Conference Tables feature a pedestal base and angular sub-top allowing the table to remain light in scale while optimizing strength and wire management. The pedestal bases and tops are finished with CCN's beautifully selected and matched wood veneers while the sub-top is finished in our Mica Chalk to blend or contrast. Pedestal bases are supported by stainless steel feet. Voice, power, and data offer superior connectivity, and beautiful matching wood doors.



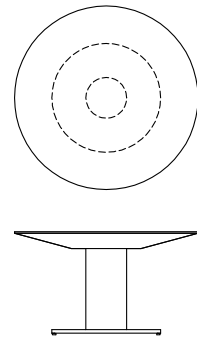
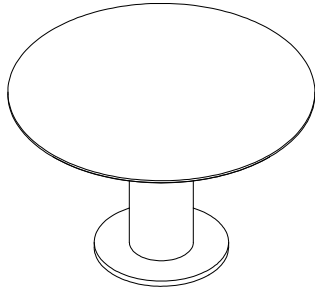

Description	Model	D	W	H	Base dia.	List Price	Weight (lbs.)
Round Conference Table 1-piece top, 1 base	ATR1S4242	42"	42"	30"	8"	\$5844	210
	ATR1S4848	48"	48"	30"	10"	\$6424	238
	ATR1S5454	54"	54"	30"	12"	\$7167	274
	ATR1S6060	60"	60"	30"	14"	\$7802	310

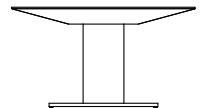
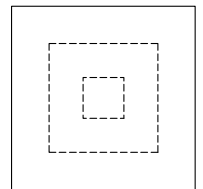
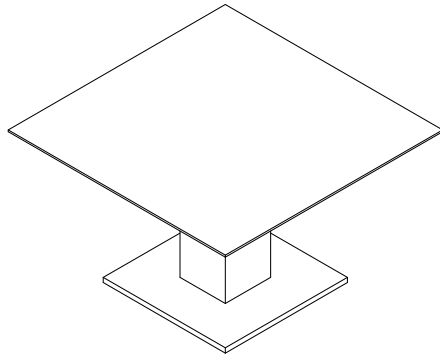

Description	Model	D	W	H	Base W	List Price	Weight (lbs.)
Square Conference Table 1-piece top, 1 base	ATS1S4242	42"	42"	30"	8"	\$5142	210
	ATS1S4848	48"	48"	30"	10"	\$5623	238
	ATS1S5454	54"	54"	30"	12"	\$6264	274
	ATS1S6060	60"	60"	30"	14"	\$6799	310

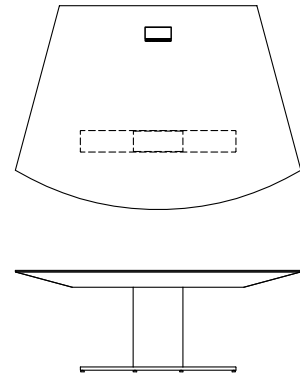
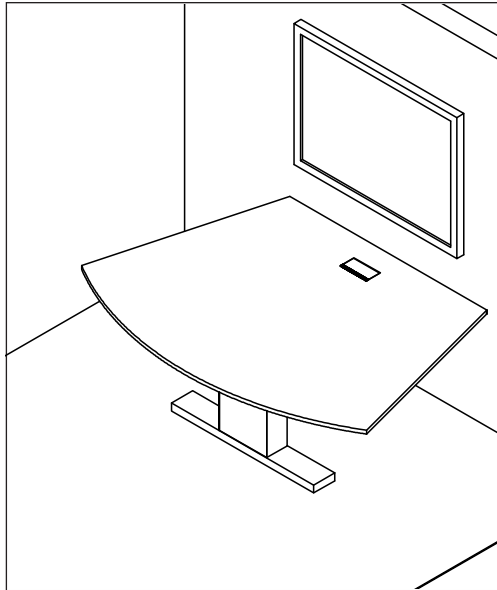

Description	Model	D	W	H	List Price	Weight (lbs.)
Wall Mounted Telepresence Conference Table 1-piece top, 1 base, 1 VPD door	ATT1S7260-0-AD1	72"	60"	30"	\$8917	291
	ATT1S7272-0-AD1	72"	72"	30"	\$9578	342
	ATT1S6084-0-AD1	60"	84"	30"	\$9174	341
	ATT1S6096-0-AD1	60"	96"	30"	\$9800	384

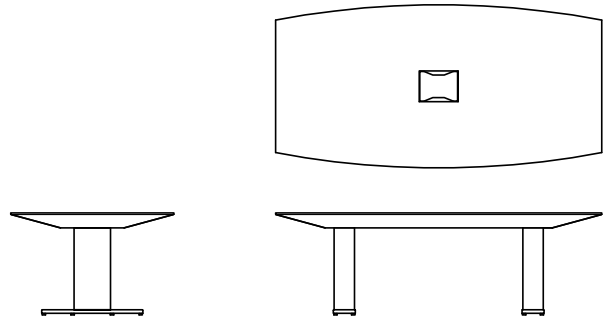
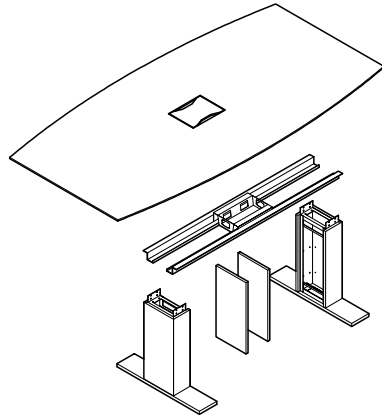

Description	Model	D	W	H	List Price	Weight (lbs.)
Curved Boat Conference Table I 1-piece top, 2 bases, 1 VPD door	ATB2S4284-0-AD1	33"/42"	84"	30"	\$10442	306
	ATB2S4884-0-AD1	39"/48"	84"	30"	\$10753	332
	ATB2S4296-0-AD1	33"/42"	96"	30"	\$11058	338
	ATB2S4896-0-AD1	39"/48"	96"	30"	\$11394	368
	ATB2S42108-0-AD1	33"/42"	108"	30"	\$11833	372
	ATS2S48108-0-AD1	39"/48"	108"	30"	\$12196	405



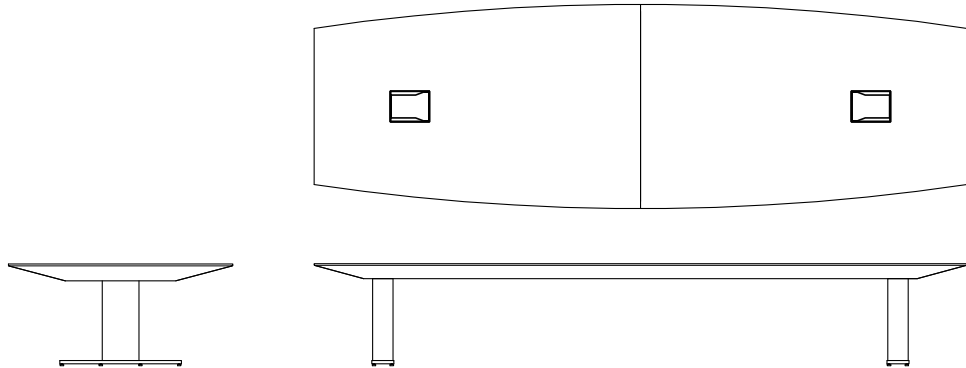
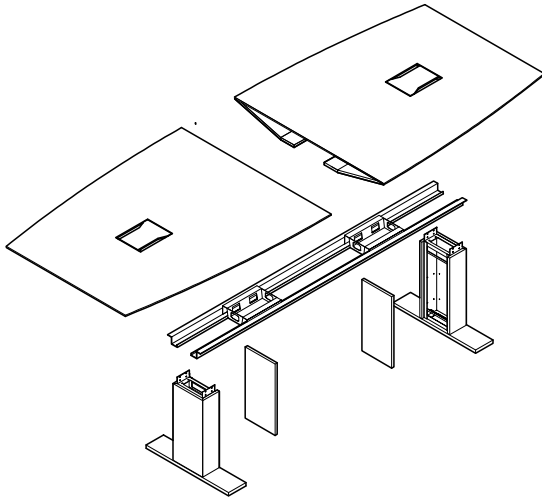

Description	Model	D	W	H	List Price	Weight (lbs.)
Curved Boat Conference Table II 2-piece top, 2 bases, 2 VPD doors	ATB2S42120-0-AD2	31"/42"	120"	30"	\$13554	404
	ATB2S48120-0-AD2	37"/48"	120"	30"	\$13946	441
	ATB2S54120-0-AD2	43"/54"	120"	30"	\$14343	479
	ATB2S42132-0-AD2	31"/42"	132"	30"	\$14332	438
	ATB2S48132-0-AD2	37"/48"	132"	30"	\$14751	479
	ATB2S54120-0-AD2	43"/54"	132"	30"	\$15178	521
	ATB2S48144-0-AD2	37"/48"	144"	30"	\$15426	515
	ATB2S54144-0-AD2	43"/54"	144"	30"	\$15881	560
	ATB2S60144-0-AD2	49"/60"	144"	30"	\$16342	605

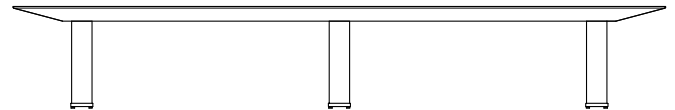
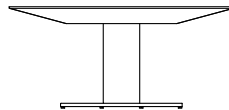
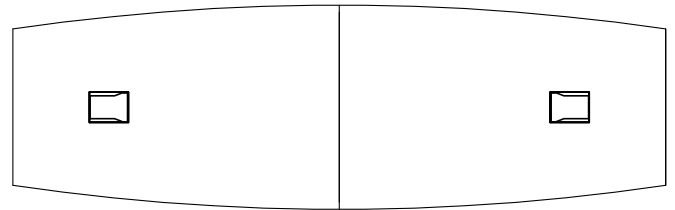
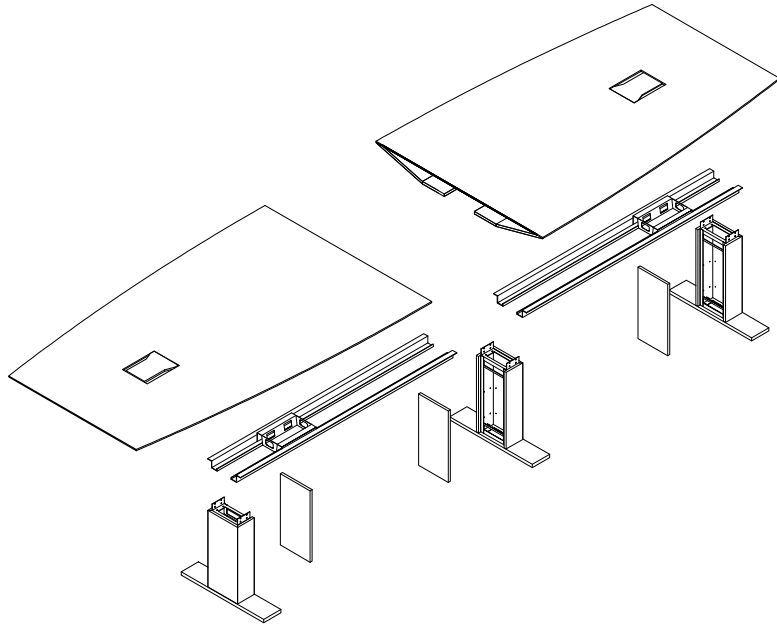

Description	Model	D	W	H	List Price	Weight (lbs.)
Curved Boat Conference Table III 2-piece top, 3 bases, 2 VPD doors	ATB3S54156-0-AD2	41"/54"	156"	30"	\$18854	646
	ATB3S60156-0-AD2	47"/60"	156"	30"	\$19907	695
	ATB3S54168-0-AD2	41"/54"	168"	30"	\$20152	686
	ATB3S60168-0-AD2	47"/60"	168"	30"	\$20691	739
	ATB3S54180-0-AD2	40"/54"	180"	30"	\$20911	726
	ATB3S60180-0-AD2	46"/60"	180"	30"	\$21485	782
	ATB3S54192-0-AD2	40"/54"	192"	30"	\$21677	766
	ATB3S60192-0-AD2	46"/60"	192"	30"	\$22286	826
	ATB3S54204-0-AD2	39"/54"	204"	30"	\$22454	805
	ATB3S60204-0-AD2	45"/60"	204"	30"	\$23095	869
	ATB3S54216-0-AD2	39"/54"	216"	30"	\$23239	845
	ATB3S60216-0-AD2	45"/60"	216"	30"	\$23918	913

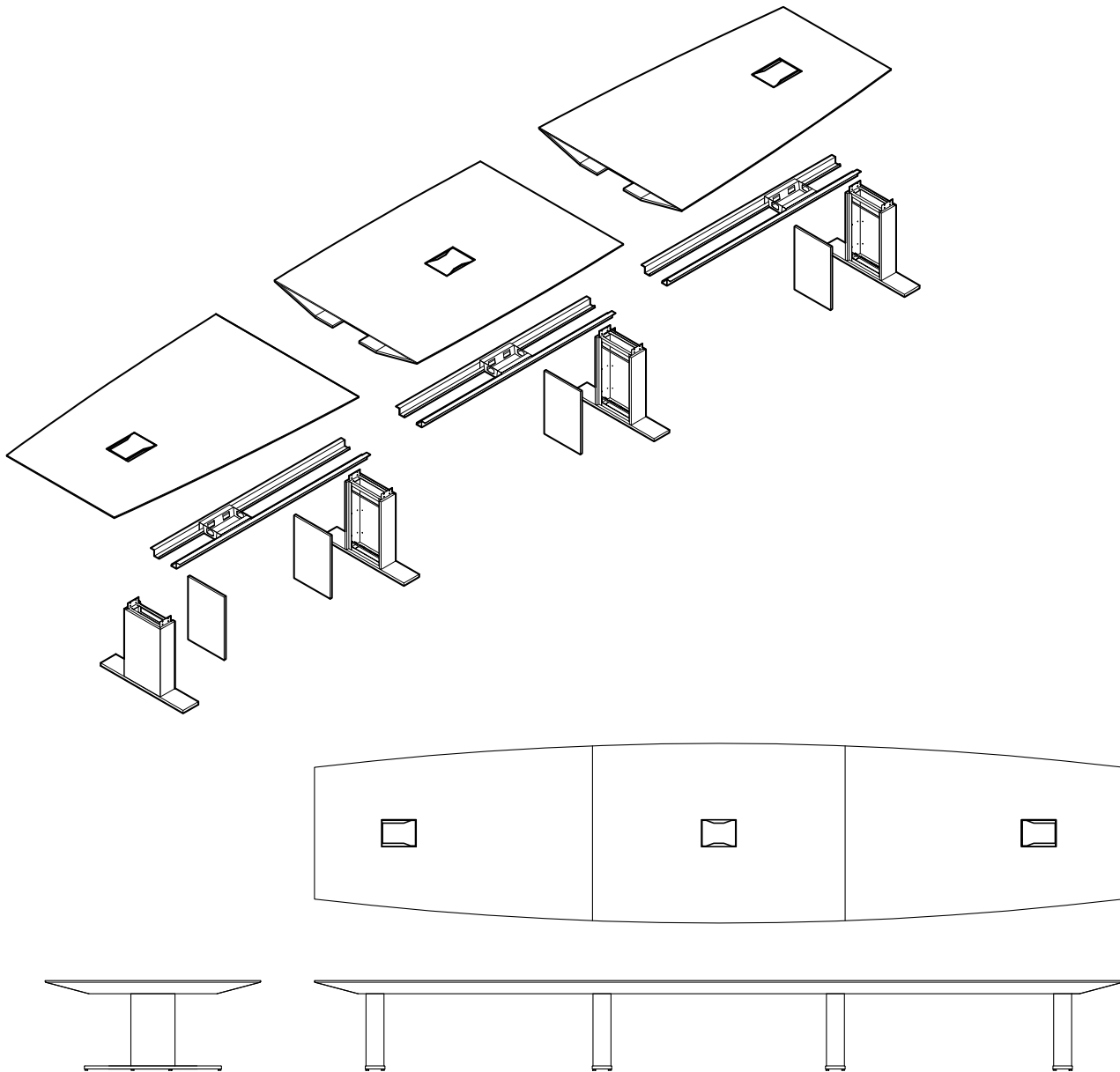

Description	Model	D	W	L	List Price	Weight (lbs.)
Curved Boat Conference Table IV 3-piece top, 4 bases, 3 VPD doors	ATB4S60240-0-AD3	44"/60"	240"	30"	\$28644	1046
	ATB4S60270-0-AD3	44"/60"	270"	30"	\$31305	1157
	ATB4S60288-0-AD3	44"/60"	288"	30"	\$32614	1222

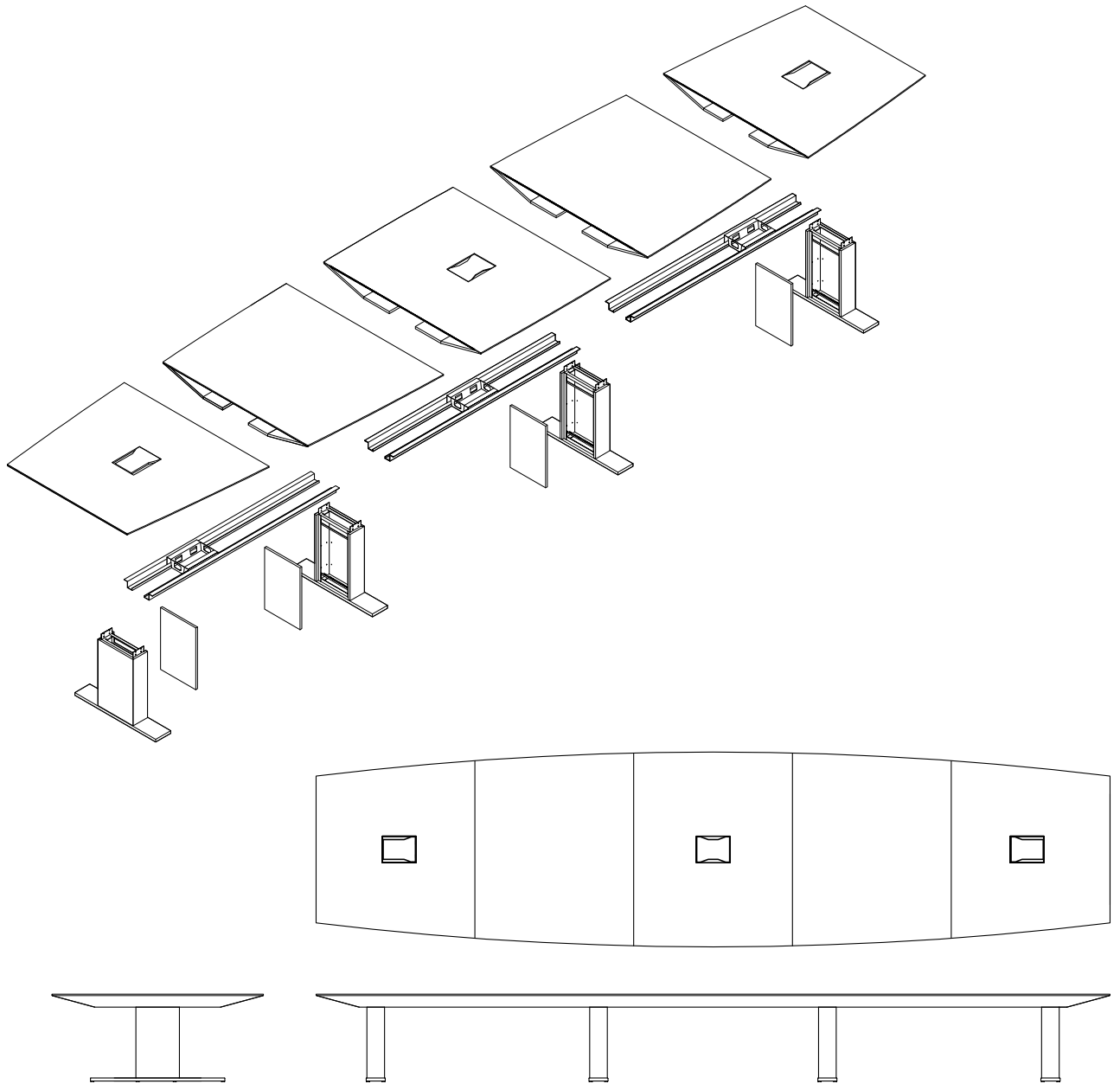

Description	Model	D	W	H	List Price	Weight (lbs.)
Curved Boat Conference Table V 5-piece top, 4 bases, 3 VPD doors	ATB4S66240-0-AD3	50"/66"	240"	30"	\$31124	1121
	ATB4S72240-0-AD3	56"/72"	240"	30"	\$31897	1196
	ATB4S66270-0-AD3	50"/66"	270"	30"	\$33884	1241
	ATB4S72270-0-AD3	56"/72"	270"	30"	\$34758	1325
	ATB4S66288-0-AD3	50"/66"	288"	30"	\$35259	1312
	ATB4S72288-0-AD3	56"/72"	288"	30"	\$36195	1402

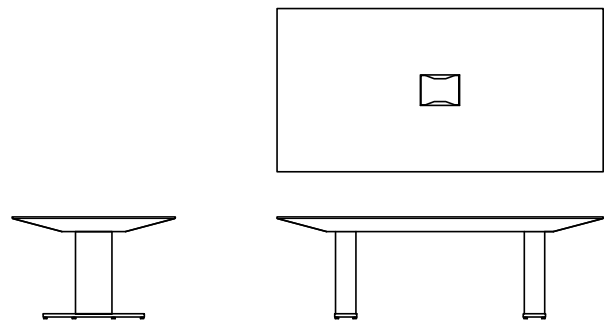
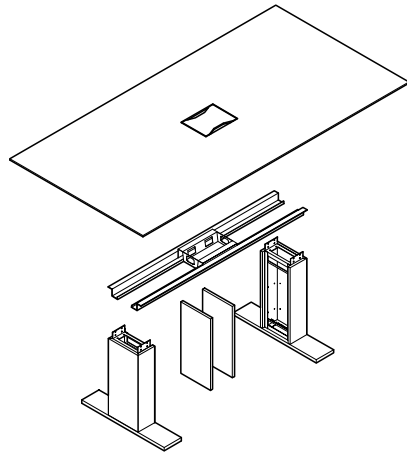

Description	Model	D	W	H	List Price	Weight (lbs.)
Rectangle Conference Table I 1-piece top, 2 bases, 1 VPD door	ATS2S4284-0-AD1	42"	84"	30"	\$9662	306
	ATS2S4884-0-AD1	48"	84"	30"	\$9973	332
	ATS2S4296-0-AD1	42"	96"	30"	\$10166	338
	ATS2S4896-0-AD1	48"	96"	30"	\$10503	368
	ATS2S42108-0-AD1	42"	108"	30"	\$10831	372
	ATS2S48108-0-AD1	48"	108"	30"	\$11194	405

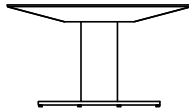
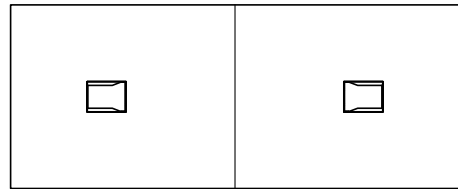
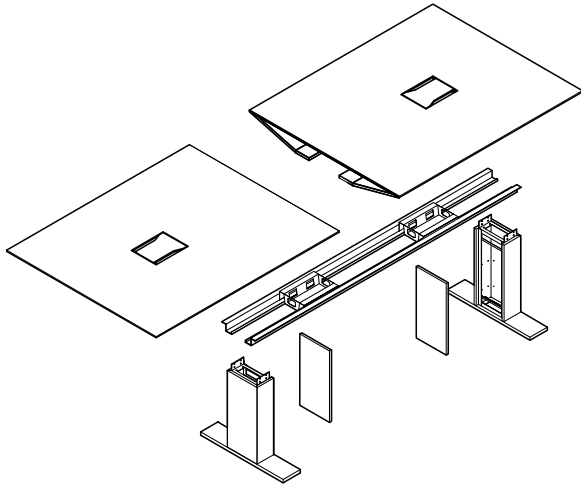

Description	Model	D	W	H	List Price	Weight (lbs.)
Rectangle Conference Table II 2-piece top, 2 bases, 2 VPD doors	ATS2S42120-0-AD2	42"	120"	30"	\$12441	404
	ATS2S48120-0-AD2	48"	120"	30"	\$12833	441
	ATS2S54120-0-AD2	54"	120"	30"	\$13230	479
	ATS2S42132-0-AD2	42"	132"	30"	\$13105	438
	ATS2S48132-0-AD2	48"	132"	30"	\$13525	479
	ATS2S54120-0-AD2	54"	132"	30"	\$13952	521
	ATS2S48144-0-AD2	48"	144"	30"	\$14086	515
	ATS2S54144-0-AD2	54"	144"	30"	\$14542	560
	ATS2S60144-0-AD2	60"	144"	30"	\$15003	605

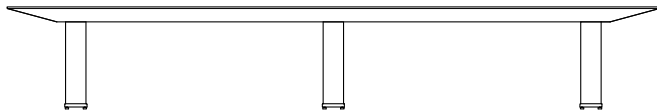
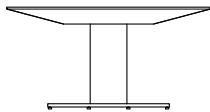
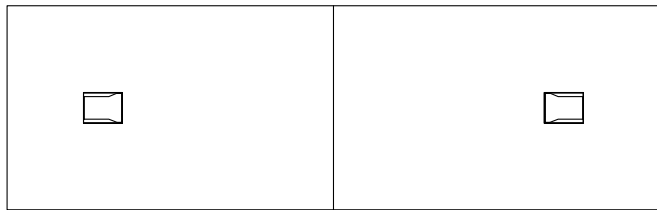
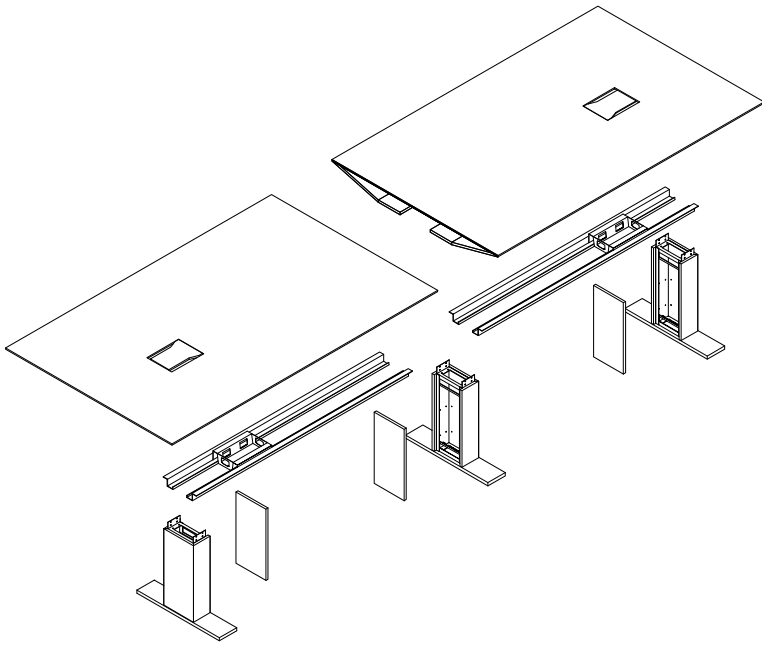

Description	Model	D	W	H	List Price	Weight (lbs.)
Rectangle Conference Table III 2-piece top, 3 bases, 2 VPD doors	ATS3S54156-0-AD2	54"	156"	30"	\$17407	646
	ATS3S60156-0-AD2	60"	156"	30"	\$18459	695
	ATS3S54168-0-AD2	54"	168"	30"	\$18592	686
	ATS3S60168-0-AD2	60"	168"	30"	\$19131	739
	ATS3S54180-0-AD2	54"	180"	30"	\$19238	726
	ATS3S60180-0-AD2	60"	180"	30"	\$19812	782
	ATS3S54192-0-AD2	54"	192"	30"	\$19896	766
	ATS3S60192-0-AD2	60"	192"	30"	\$20505	826
	ATS3S54204-0-AD2	54"	204"	30"	\$20560	805
	ATS3S60204-0-AD2	60"	204"	30"	\$21202	869
	ATS3S54216-0-AD2	54"	216"	30"	\$21232	845
	ATS3S60216-0-AD2	60"	216"	30"	\$21911	913

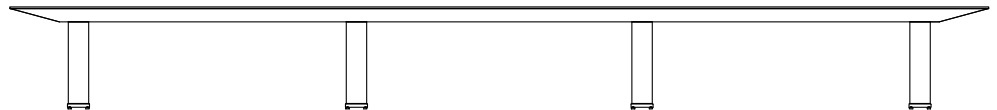
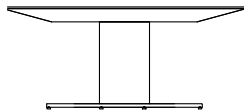
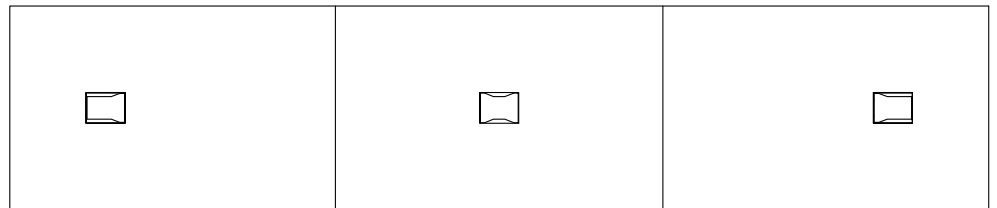
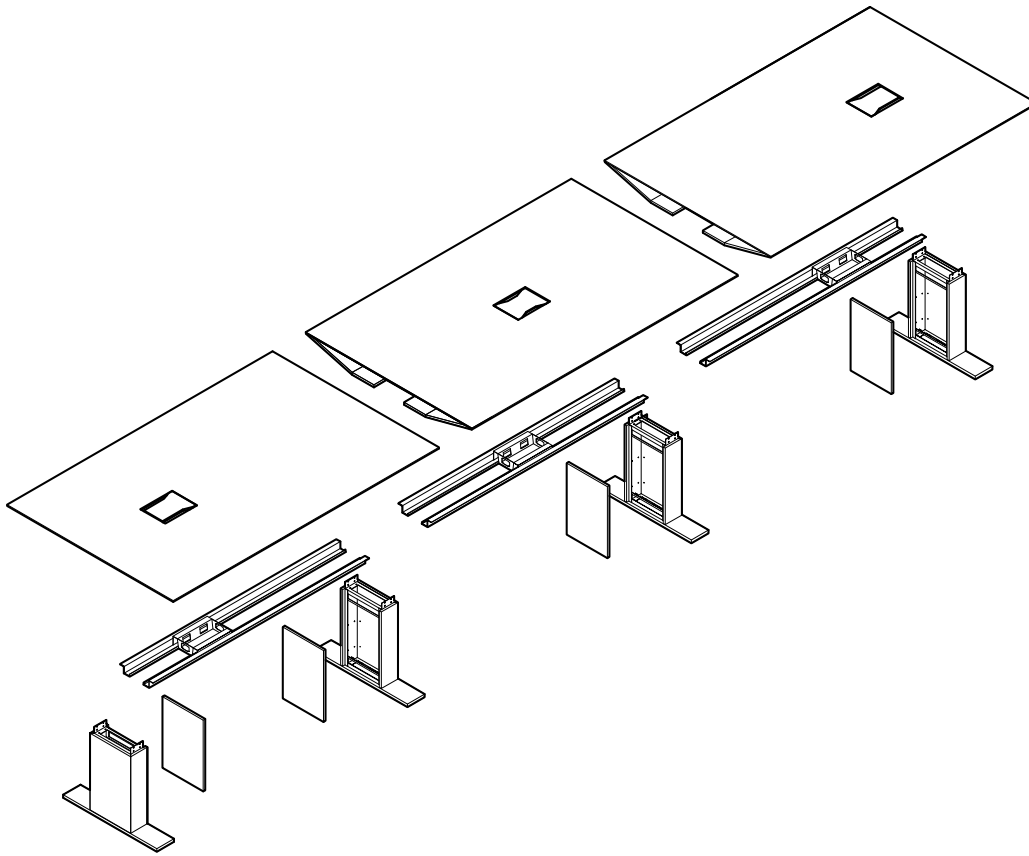

Description	Model	D	W	H	List Price	Weight (lbs.)
Rectangle Conference Table IV 3-piece top, 4 bases, 3 VPD doors	ATS4S60240-0-AD3	60"	240"	30"	\$26416	1046
	ATS4S60270-0-AD3	60"	270"	30"	\$28797	1157
	ATS4S60288-0-AD3	60"	288"	30"	\$29939	1222

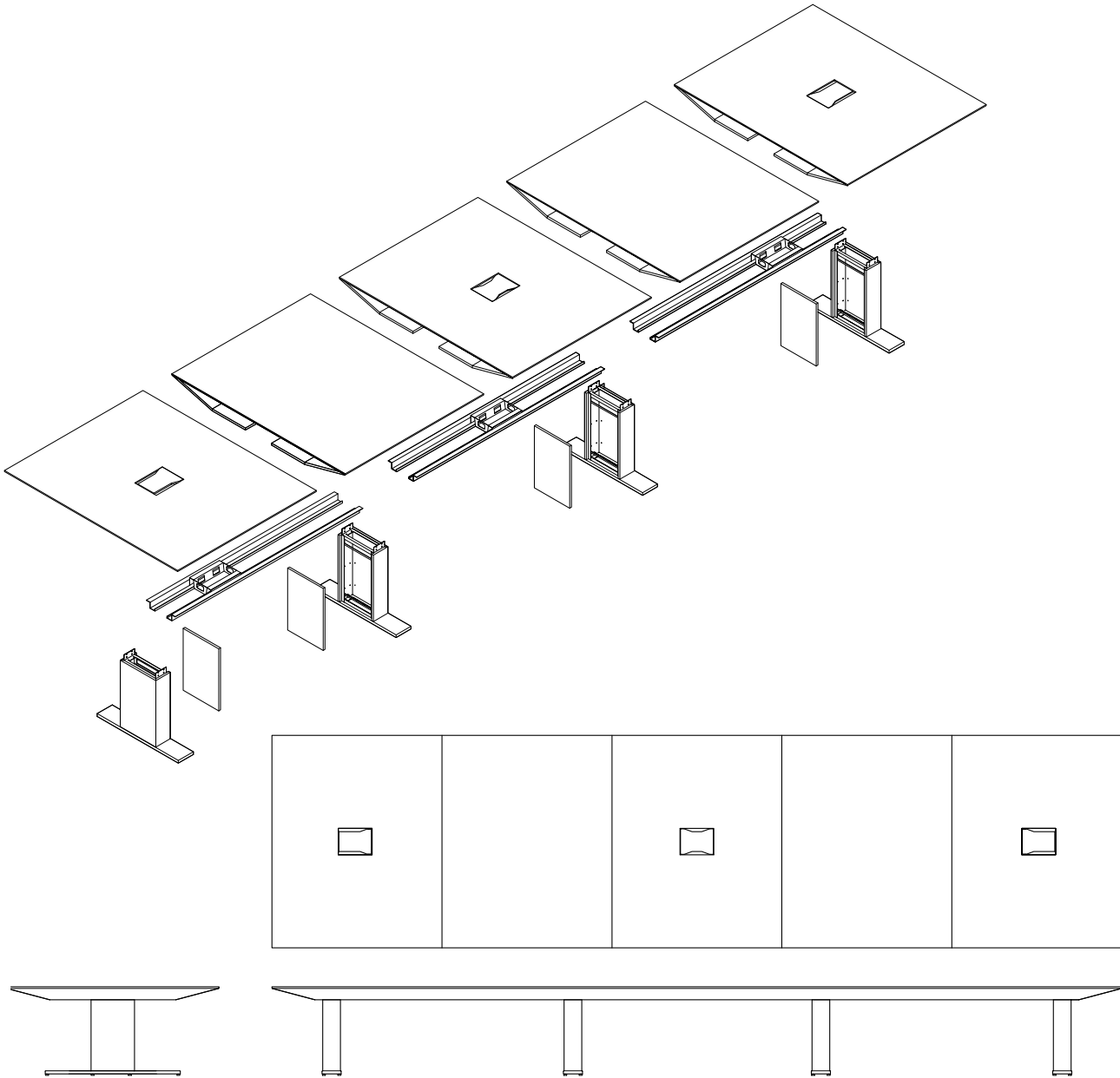

Description	Model	D	W	H	List Price	Weight (lbs.)
Rectangle Conference Table V 5-piece top, 4 bases, 3 VPD doors	ATS4S66240-0-AD3	66"	240"	30"	\$28895	1121
	ATS4S72240-0-AD3	72"	240"	30"	\$29668	1196
	ATS4S66270-0-AD3	66"	270"	30"	\$31376	1241
	ATS4S72270-0-AD3	72"	270"	30"	\$32250	1325
	ATS4S66288-0-AD3	66"	288"	30"	\$32584	1312
	ATS4S72288-0-AD3	72"	288"	30"	\$33520	1402

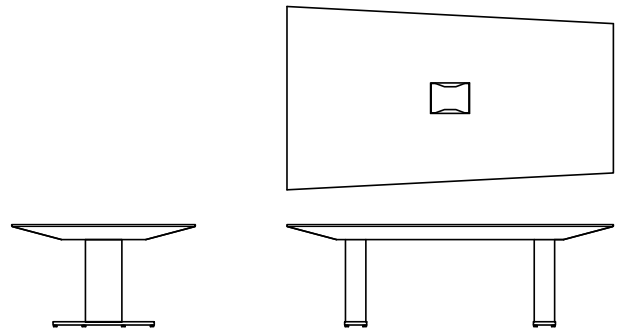
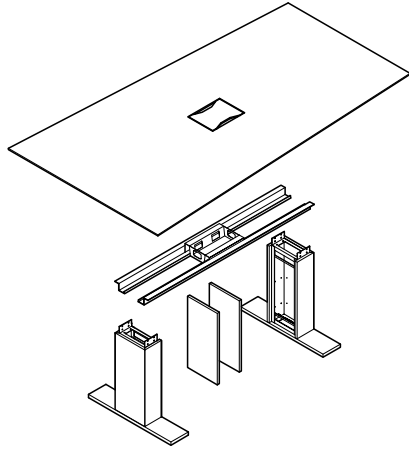

Description	Model	D	W	H	List Price	Weight (lbs.)
Wedge Conference Table I 1-piece top, 2 bases, 1 VPD door	ATW2S4884-0-AD1	39"/48"	84"	30"	\$9973	332
	ATW2S5484-0-AD1	45"/54"	84"	30"	\$10288	359
	ATW2S4896-0-AD1	38"/48"	96"	30"	\$10503	368
	ATW2S5496-0-AD1	44"/54"	96"	30"	\$10845	398
	ATW2S48108-0-AD1	36½"/48"	108"	30"	\$11194	405
	ATW2S54108-0-AD1	42½"/54"	108"	30"	\$11561	439



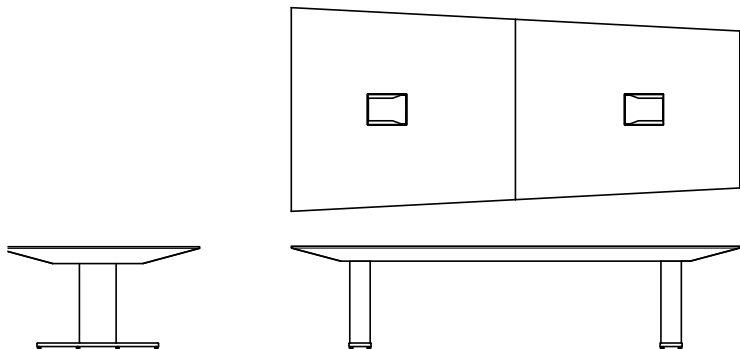
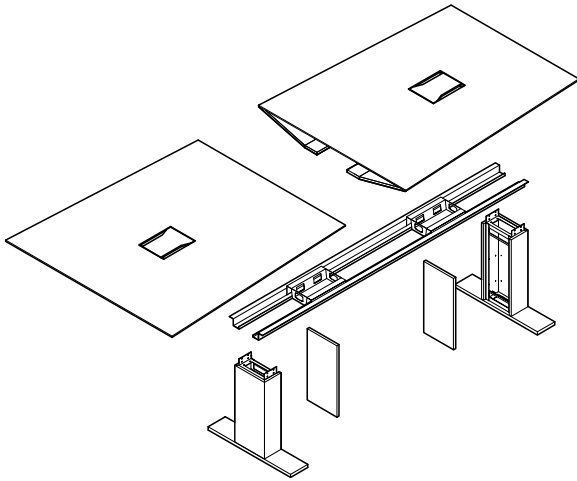

Description	Model	D	W	H	List Price	Weight (lbs.)
Wedge Conference Table II 2-piece top, 2 bases, 2 VPD doors	ATW2S48120-0-AD1	35½"/48"	120"	30"	\$12833	441
	ATW2S54120-0-AD1	41½"/54"	120"	30"	\$13230	479
	ATW2S54132-0-AD1	40"/54"	132"	30"	\$13952	521
	ATW2S60132-0-AD1	46"/60"	132"	30"	\$14380	562
	ATW2S54144-0-AD1	39"/54"	144"	30"	\$14542	560
	ATW2S60144-0-AD1	45"/60"	144"	30"	\$15003	605

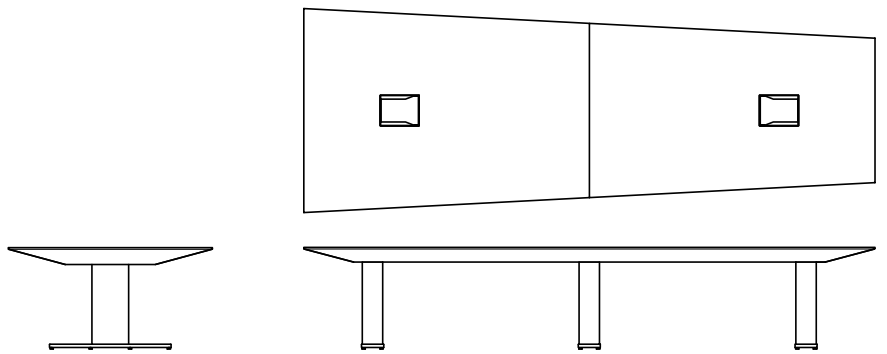
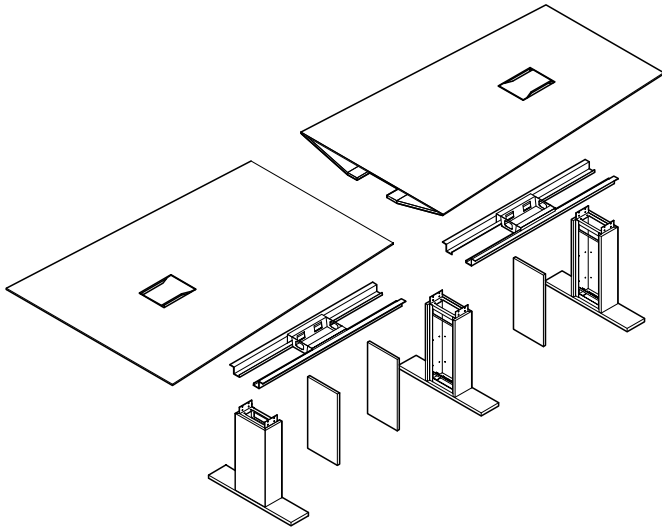

Description	Model	D	W	H	List Price	Weight (lbs.)
Wedge Conference Table III 2-piece top, 3 bases, 2 VPD doors	ATW3S60156-0-AD2	43½"/60"	156"	30"	\$18459	695
	ATW3S60168-0-AD2	42½"/60"	168"	30"	\$19131	739
	ATW3S60180-0-AD2	41"/60"	180"	30"	\$19812	782

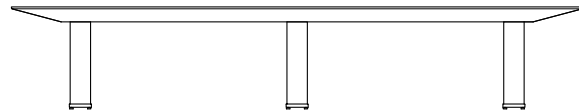
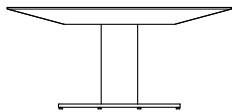
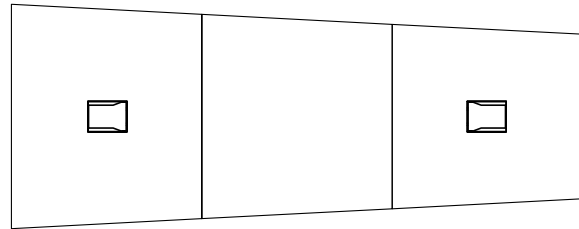
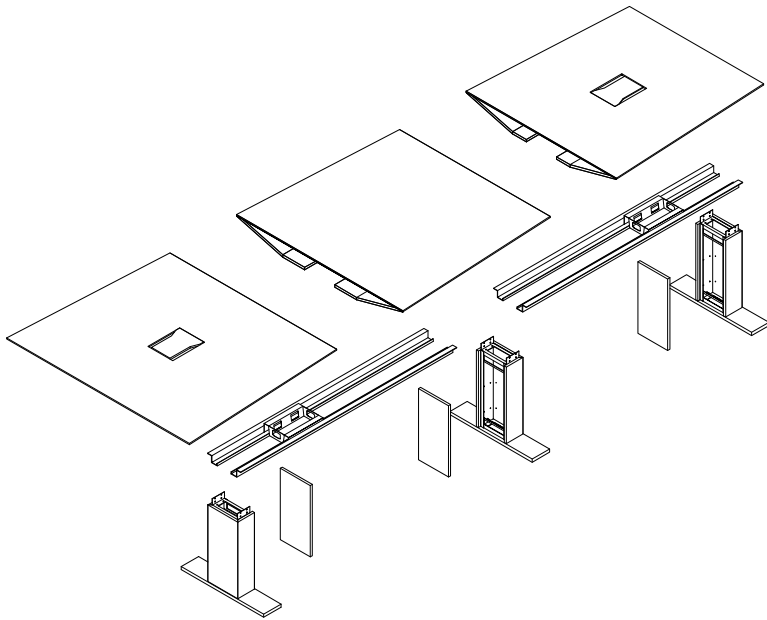

Description	Model	W	D	H	List Price	Weight (lbs.)
Wedge Conference Table IV 3-piece top, 3 bases, 2 VPD doors	ATW3S66156-0-AD2	49½"/66"	156"	30"	\$20262	744
	ATW3S66168-0-AD2	48½"/66"	168"	30"	\$20965	791
	ATW3S66180-0-AD2	47"/66"	180"	30"	\$21680	838

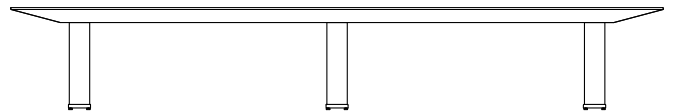
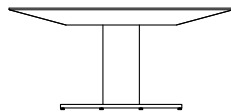
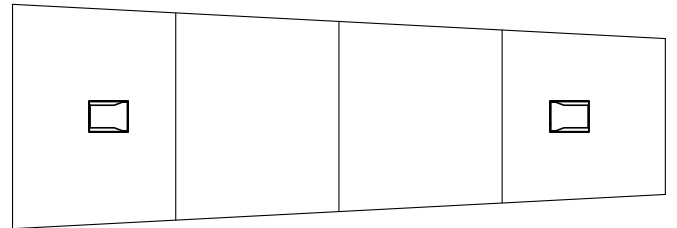
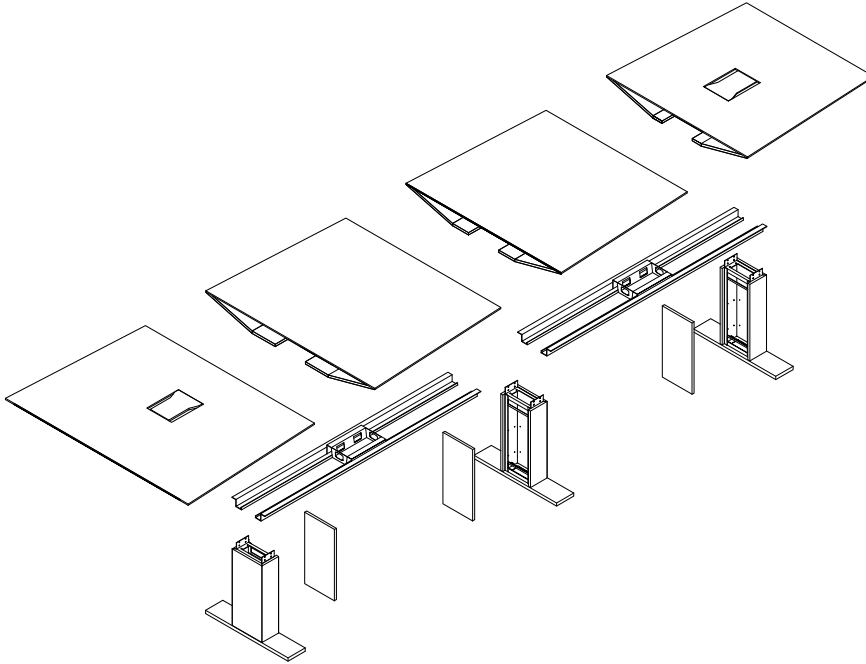

Description	Model	D	W	H	List Price	Weight (lbs.)
Wedge Conference Table V 4-piece top, 3 bases, 2 VPD doors	ATW3S66192-0-AD2	46"/66"	192"	30"	\$22407	886
	ATW3S72192-0-AD2	52"/72"	192"	30"	\$23030	946
	ATW3S66204-0-AD2	44½"/66"	204"	30"	\$23143	933
	ATW3S72204-0-AD2	50½"/72"	204"	30"	\$23801	997
	ATW3S66216-0-AD2	43½"/66"	216"	30"	\$23887	980
	ATW3S72216-0-AD2	49½"/72"	216"	30"	\$24583	1048



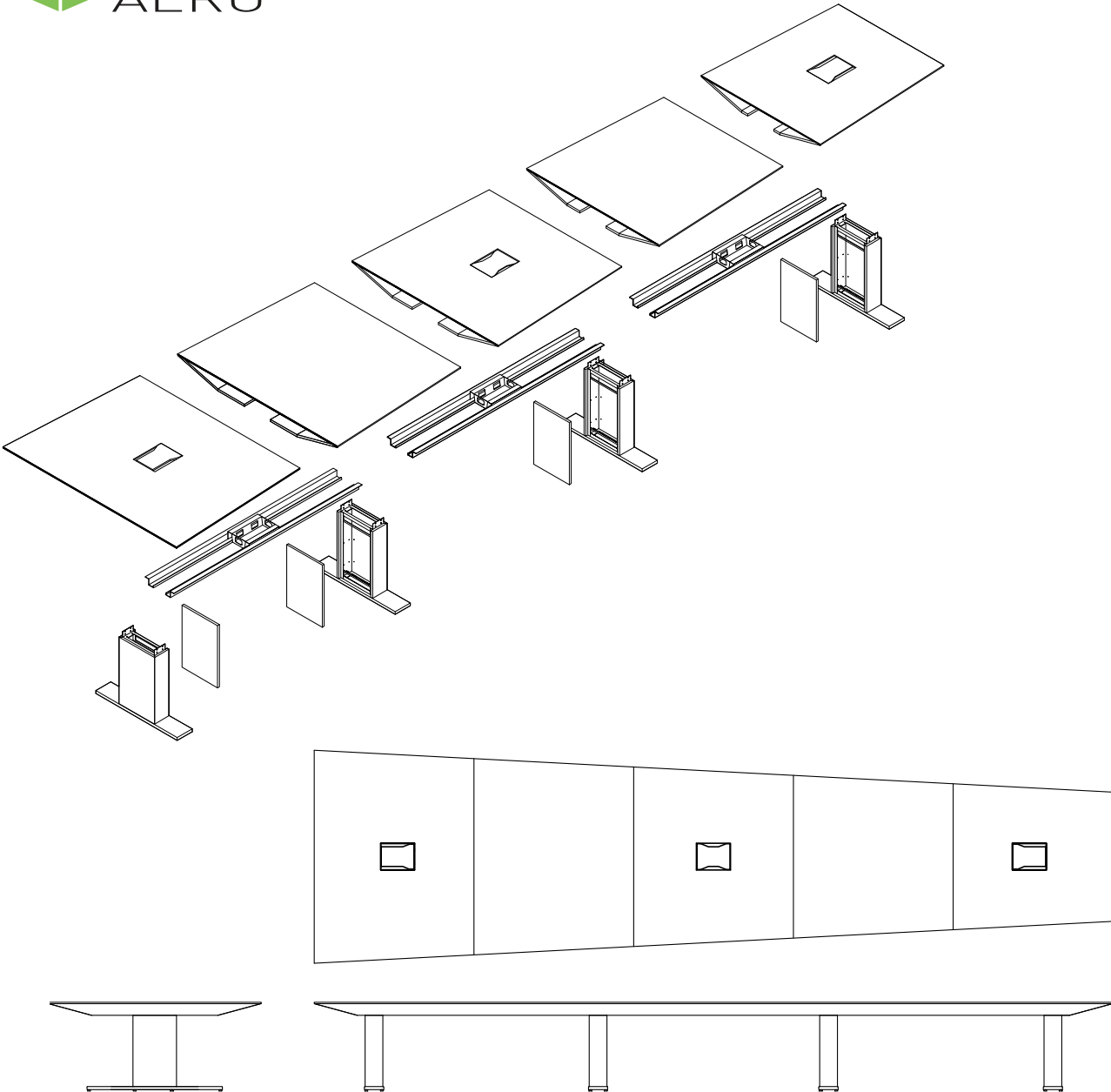

Description	Model	D	W	H	List Price	Weight (lbs.)
Wedge Conference Table VI 5-piece top, 4 bases, 3 VPD doors	ATW4S66240-0-AD3	41"/66"	240"	30"	\$28895	1121
	ATW4S72240-0-AD3	47"/72"	240"	30"	\$29668	1196
	ATW4S78240-0-AD3	53"/78"	240"	30"	\$30450	1271
	ATW4S66270-0-AD3	38"/66"	270"	30"	\$31376	1241
	ATW4S72270-0-AD3	44"/72"	270"	30"	\$32250	1325
	ATW4S78270-0-AD3	50"/78"	270"	30"	\$33134	1410
	ATW4S66288-0-AD3	36"/66"	288"	30"	\$32584	1312
	ATW4S72288-0-AD3	42"/72"	288"	30"	\$33520	1402
	ATW4S78288-0-AD3	48"/78"	288"	30"	\$34470	1492

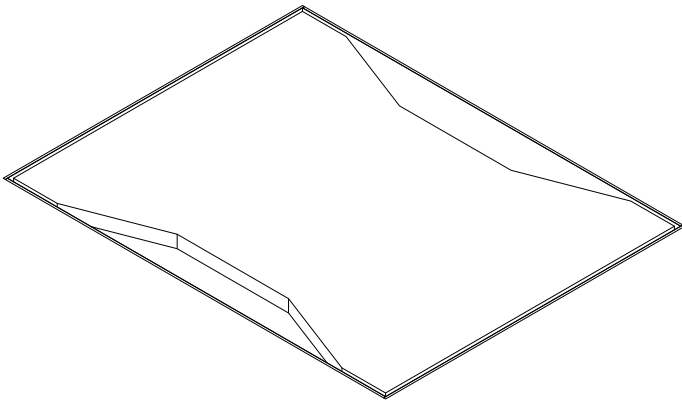

Description	Model	List Price
Additional Voice Power and Data Fixture for Intermediate Application	ADI	\$1091

Media Units

Media Units are available with two credenza heights. The 36" buffet height is the perfect compliment to a conference table. The 20" high credenza is ideal for use in public areas, or other stand alone situations. They make a strong statement with clean lines and angular details. Media Units are available with outer bookcase ends providing ample storage and an optional video-conferencing camera shelf.

All units shown with optional camera shelf.

See page 36 for all optional details



Description	Model	D	W	H	List Price	Weight (lbs.)
 <p>Media Unit I with 36" buffet height credenza</p>	AVDC4S-246086-HH	24"	60"	85½"	\$10566	336
 <p>Media Unit II with 36" buffet height credenza</p>	AVDC4S-247286-GGGG	24"	72"	85½"	\$10808	378
	AVDC4S-248486-GGGG	24"	84"	85½"	\$11080	410
 <p>Media Unit III with end bookcases</p>	AVDX40-2410686-HH	24"	106"	85½"	\$19016	760
 <p>Media Unit IV with end bookcases</p>	AVDX40-2411886-GGGG	24"	118"	85½"	\$19254	802
	AVDX40-2413086-GGGG	24"	130"	85½"	\$19532	835

All units shown with optional camera shelf. See page 36 for additional options.

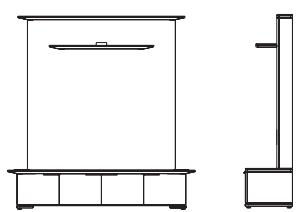
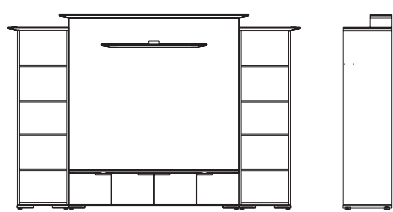
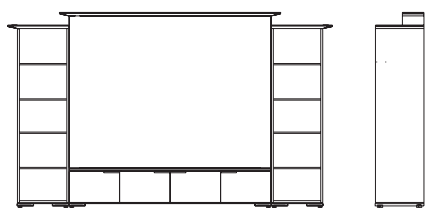
Description	Model	D	W	H	List Price	Weight (lbs.)
 <p data-bbox="89 577 292 640">Media Unit V with 20" H credenza</p>	AVDC1S-187274-HHHH	18"	72"	74"	\$9733	369
 <p data-bbox="89 913 292 976">Media Unit VI with 20" H credenza</p>	AVDC1S-188474-HHHH	18"	84"	74"	\$10008	400
 <p data-bbox="89 1249 292 1312">Media Unit VII with end bookcases</p>	AVDX10-1811874-HHHH	18"	118"	74"	\$16834	667
 <p data-bbox="89 1585 292 1648">Media Unit VIII with end bookcases</p>	AVDX10-1813074-HHHH	18"	130"	74"	\$17107	698

All units shown with optional camera shelf. See page 36 for additional options.

Media Unit Optional Details

Media Units come standard with wood shelves.

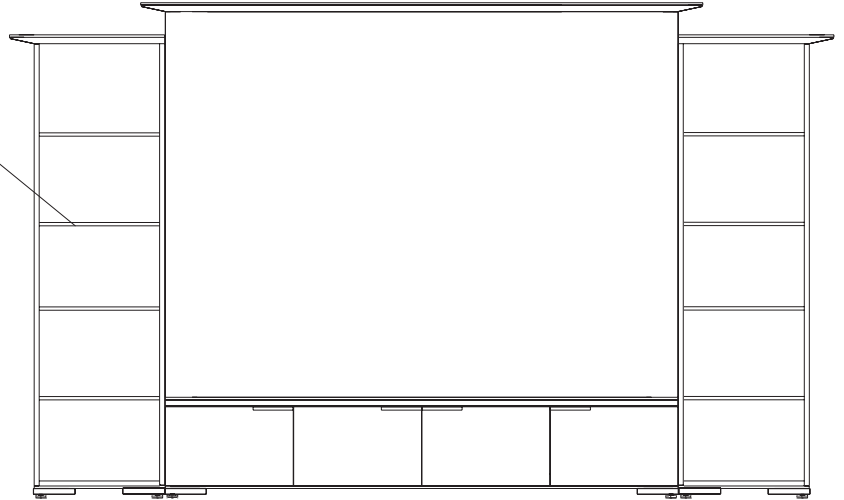

Optional glass shelves and halogen light package may be specified. Optional hinged doors are also available for the end bookcases.

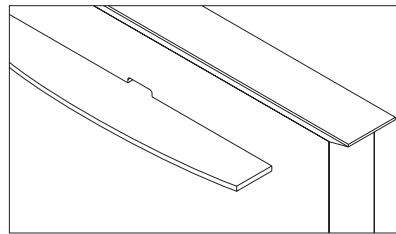

Radiused $\frac{3}{4}$ " tempered glass camera shelf

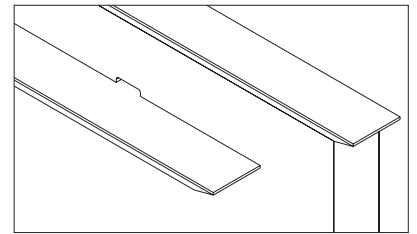



Wood camera shelf

Description	Model	D	W	H	List Price
Wood Camera Shelf	AACSW	8"	45"	1 $\frac{3}{8}$ "	\$450
Glass Camera Shelf	AACSG	8"	45"	1 $\frac{3}{4}$ "	\$1000
Glass & Light Package I for 66"H unit— Price reflects both sides	AAGP1			66"	\$1150
Glass & Light Package II for 77 $\frac{1}{2}$ "H unit— Price reflects both sides	AAGP2			77 $\frac{1}{2}$ "	\$1150
Bookend Doors I for 66"H unit— Price reflects both sides	AABD1	$\frac{3}{4}$ "	20"	66"	\$1000
Bookend Doors II for 77 $\frac{1}{2}$ "H unit— Price reflects both sides	AABD2	$\frac{3}{4}$ "	20"	77 $\frac{1}{2}$ "	\$1090

Buffet Credenza

AERO Buffet Credenzas feature a similar aesthetic as the tables. The DuoTone finish adds a floating quality to the top and the light scale. The top is flush along the case front with angular details overhanging on the sides. A metal reveal accents the bottom of the case.



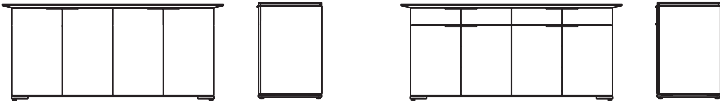
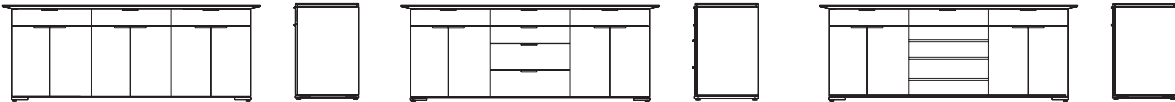

Description	Model		D	W	H	List Price	Weight (lbs.)
	ACOV-246036-HH		24"	60"	36"	\$6206	190
	ACOV-246036-HcH		24"	60"	36"	\$6629	220
	ACOV-247236-HHHH		24"	72"	36"	\$5746	204
	ACOV-247236-GGGG		24"	72"	36"	\$6370	214
	ACOV-248436-HHHH		24"	84"	36"	\$5940	218
	ACOV-248436-GGGG		24"	84"	36"	\$6564	228
	ACOV-249636-GGGGGG		24"	96"	36"	\$8168	262
	ACOV-249636-GGtGG		24"	96"	36"	\$9396	372
	ACOV-249636-GGjGG		24"	96"	36"	\$8799	342

Conference Compliments

The AERO collection includes various complimentary items to complete any conference room. The Lectern features an angular sub-top, pedestal and accent base that compliments the table. The Serving Carts provide convenient, portable storage with an integral handle built in the top end overhangs. Hospitality Tables add a functional finishing touch that matches the AERO aesthetic and ties the room together with a strong design statement.

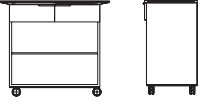

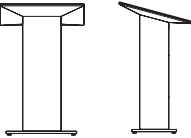
Description	Model	D	W	H	List Price	Weight (lbs.)
	AVSNC1-204636	20"	46"	36"	\$4312	158
	AVSHC1-204636	20"	46"	36"	\$4913	178
	ATS4L-216036-JJJ	21"	60"	36"	\$5999	134
	ATS4L-217236-JJJJ	21"	72"	36"	\$6860	162
	AVP-293248	29"	32"	48"	\$3971	100

CCN International manufactures high-quality office furniture for management, executive, conference and reception areas. We are known for our level of detail, our flexibility and our shared appreciation for the beauty and warmth of wood furniture. The philosophy is evident throughout our product line, ranging from traditional to contemporary to artisan style office furniture.

For more information visit www.ccnintl.com.



CCN International Inc.
200 Lehigh Street
Geneva, NY 14456
315-789-4400
www.ccnintl.com